

PIONEER POINTE

ALL OF LOT 1 OF CERTIFIED SURVEY MAP NO. 6405 RECORDED IN VOLUME 31 ON PAGES 114-116 OF CERTIFIED SURVEY MAPS OF DANE COUNTY AS DOCUMENT NO. 2263455, LOT 1 OF CERTIFIED SURVEY MAP NO. 6406 RECORDED IN VOLUME 31 ON PAGES 117-119 OF CERTIFIED SURVEY MAPS OF DANE COUNTY AS DOCUMENT NO. 2263456, LOT 3 OF CERTIFIED SURVEY MAP NO. 14062 RECORDED IN VOLUME 94 ON PAGES 180-182 OF CERTIFIED SURVEY MAPS OF DANE COUNTY AS DOCUMENT NO. 5180509, LOT 1 OF CERTIFIED SURVEY MAP NO. 14753 RECORDED IN VOLUME 103 ON PAGES 39-42 OF CERTIFIED SURVEY MAPS OF DANE COUNTY AS DOCUMENT NO. 5398764, AND OTHER UNPLATTED LANDS BEING LOCATED IN THE NORTHWEST QUARTER OF THE NORTHWEST QUARTER, THE NORTHEAST QUARTER OF THE NORTHWEST QUARTER, THE SOUTHWEST QUARTER OF THE NORTHWEST QUARTER, THE SOUTHWEST QUARTER OF THE NORTHWEST QUARTER AND THE SOUTHWEST QUARTER OF SECTION 29, AND THE NORTHEAST QUARTER OF THE NORTHWEST QUARTER AND SOUTHWEST QUARTER OF SECTION 30 ALL IN TOWN 7 NORTH, RANGE 8 EAST, TOWN OF MIDDLETON, DANE COUNTY, WISCONSIN

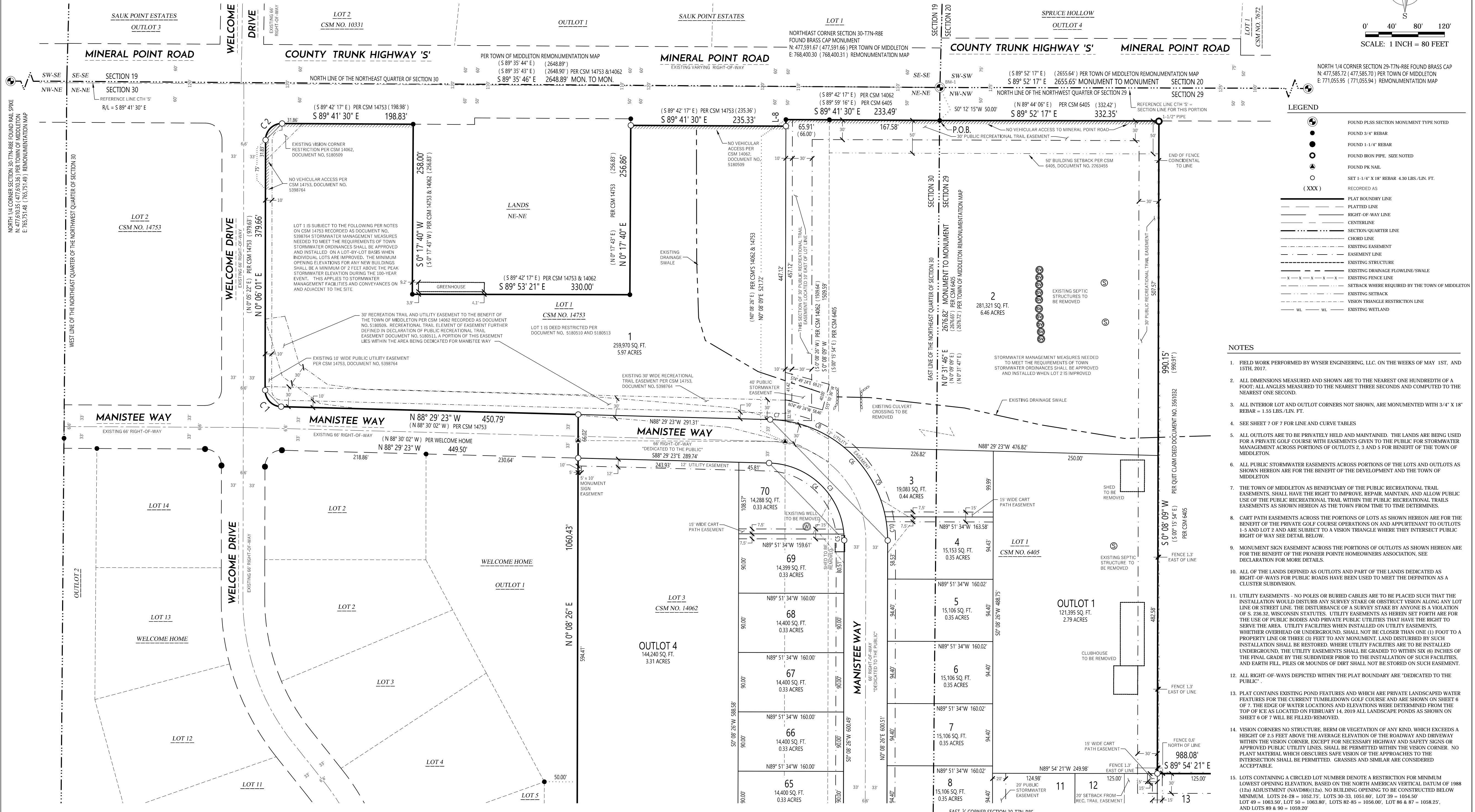
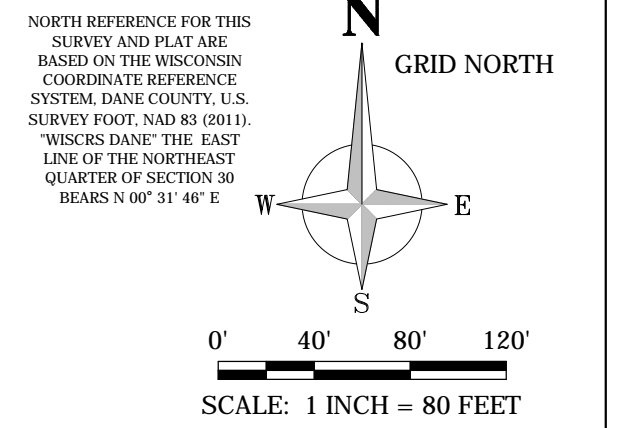

- ### LEGEND
- FOUND PLUS SECTION MONUMENT TYPE NOTED
 - FOUND 3/4" REBAR
 - FOUND 1/4" REBAR
 - FOUND IRON PIPE, SIZE NOTED
 - FOUND PK NAIL
 - SET 1-1/4" X 18" REBAR 4.30 LBS./LIN. FT.
 - (XXX) RECORDED AS
 - PLAT BOUNDARY LINE
 - PLATTED LINE
 - RIGHT-OF-WAY LINE
 - CENTERLINE
 - SECTION/QUARTER LINE
 - CHORD LINE
 - EXISTING EASEMENT
 - EASEMENT LINE
 - EXISTING STRUCTURE
 - EXISTING DRAINAGE FLOWLINE/SWALE
 - EXISTING FENCE LINE
 - SETBACK WIDTH REQUIRED BY THE TOWN OF MIDDLETON
 - EXISTING SETBACK
 - VISION TRIANGLE RESTRICTION LINE
 - WL WL EXISTING WETLAND

- ### NOTES
1. FIELD WORK PERFORMED BY WYSER ENGINEERING, LLC. ON THE WEEKS OF MAY 1ST, AND 15TH, 2017.
 2. ALL DIMENSIONS MEASURED AND SHOWN ARE TO THE NEAREST ONE HUNDREDTH OF A FOOT; ALL ANGLES MEASURED TO THE NEAREST THREE SECONDS AND COMPUTED TO THE NEAREST ONE SECOND.
 3. ALL INTERIOR LOT AND OUTLOT CORNERS NOT SHOWN, ARE MONUMENTED WITH 3/4" X 18" REBAR = 1.55 LBS./LIN. FT.
 4. SEE SHEET 7 OF 7 FOR LINE AND CURVE TABLES.
 5. ALL OUTLOTS ARE TO BE PRIVATELY HELD AND MAINTAINED. THE LANDS ARE BEING USED FOR A PRIVATE GOLF COURSE WITH EASEMENTS GIVEN TO THE PUBLIC FOR STORMWATER MANAGEMENT ACROSS PORTIONS OF OUTLOTS 2, 3 AND 5 FOR BENEFIT OF THE TOWN OF MIDDLETON.
 6. ALL PUBLIC STORMWATER EASEMENTS ACROSS PORTIONS OF THE LOTS AND OUTLOTS AS SHOWN HEREON ARE FOR THE BENEFIT OF THE DEVELOPMENT AND THE TOWN OF MIDDLETON.
 7. THE TOWN OF MIDDLETON AS BENEFICIARY OF THE PUBLIC RECREATIONAL TRAIL EASEMENTS, SHALL HAVE THE RIGHT TO IMPROVE, REPAIR, MAINTAIN, AND ALLOW PUBLIC USE OF THE PUBLIC RECREATIONAL TRAIL WITHIN THE PUBLIC RECREATIONAL TRAIL EASEMENTS AS SHOWN HEREON AS THE TOWN FROM TIME TO TIME DETERMINES.
 8. CART PATH EASEMENTS ACROSS THE PORTIONS OF LOTS AS SHOWN HEREON ARE FOR THE BENEFIT OF THE PRIVATE GOLF COURSE OPERATIONS ON AND APPURTENANT TO OUTLOTS 1-5 AND LOT 2 AND ARE SUBJECT TO A VISION TRIANGLE WHERE THEY INTERSECT PUBLIC RIGHT OF WAY SEE DETAIL BELOW.
 9. MONUMENT SIGN EASEMENT ACROSS THE PORTIONS OF OUTLOTS AS SHOWN HEREON ARE FOR THE BENEFIT OF THE PIONEER POINTE HOMEOWNERS ASSOCIATION. SEE DECLARATION FOR MORE DETAILS.
 10. ALL OF THE LANDS DEFINED AS OUTLOTS AND PART OF THE LANDS DEDICATED AS RIGHT-OF-WAYS FOR PUBLIC ROADS HAVE BEEN USED TO MEET THE DEFINITION AS A CLUSTER SUBDIVISION.
 11. UTILITY EASEMENTS - NO POLES OR BURIED CABLES ARE TO BE PLACED SUCH THAT THE INSTALLATION WOULD DISTURB ANY SURVEY STAKE OR OBSTRUCT VISION ALONG ANY LOT LINE OR STREET LINE. THE DISTURBANCE OF A SURVEY STAKE BY ANYONE IS A VIOLATION OF S. 236.32, WISCONSIN STATUTES. UTILITY EASEMENTS AS HEREIN SET FORTH ARE FOR THE USE OF PUBLIC BODIES AND PRIVATE PUBLIC UTILITIES THAT HAVE THE RIGHT TO SERVE THE AREA. UTILITY FACILITIES WHEN INSTALLED ON UTILITY EASEMENTS, WHETHER OVERHEAD OR UNDERGROUND, SHALL NOT BE CLOSER THAN ONE (1) FOOT TO A PROPERTY LINE OR THREE (3) FEET TO ANY MONUMENT. LAND DISTURBED BY SUCH INSTALLATION SHALL BE RESTORED. WHERE UTILITY FACILITIES ARE TO BE INSTALLED UNDERGROUND, THE UTILITY EASEMENTS SHALL BE GRADED TO WITHIN SIX (6) INCHES OF THE FINAL GRADE BY THE SUBMITTER PRIOR TO THE INSTALLATION OF SUCH FACILITIES, AND EARTH FILL, PILES OR MOUNDS OF DIRT SHALL NOT BE STORED ON SUCH EASEMENT.
 12. ALL RIGHT-OF-WAYS DEPICTED WITHIN THE PLAT BOUNDARY ARE "DEDICATED TO THE PUBLIC".
 13. PLAT CONTAINS EXISTING POND FEATURES AND WHICH ARE PRIVATE LANDSCAPED WATER FEATURES FOR THE CURRENT TUMBLEDOWN GOLF COURSE AND ARE SHOWN ON SHEET 6 OF 7. THE EDGE OF WATER LOCATIONS AND ELEVATIONS WERE DETERMINED FROM THE TOP OF ICE AS LOCATED ON FEBRUARY 14, 2019 ALL LANDSCAPE PONDS AS SHOWN ON SHEET 6 OF 7 WILL BE FILLED/REMOVED.
 14. VISION CORNERS NO STRUCTURE, BERM OR VEGETATION OF ANY KIND, WHICH EXCEEDS A HEIGHT OF 2.5 FEET ABOVE THE AVERAGE ELEVATION OF THE ROADWAY AND DRIVEWAY WITHIN THE VISION CORNER, EXCEPT FOR NECESSARY HIGHWAY AND SAFETY SIGNS OR APPROVED PUBLIC UTILITY LINES, SHALL BE PERMITTED WITHIN THE VISION CORNER. NO PLANT MATERIAL WHICH OBSCURES SAFE VISION OF THE APPROACHES TO THE INTERSECTION SHALL BE PERMITTED. GRASSES AND SIMILAR ARE CONSIDERED ACCEPTABLE.
 15. LOTS CONTAINING A CIRCLED LOT NUMBER DENOTE A RESTRICTION FOR MINIMUM LOWEST OPENING ELEVATION, BASED ON THE NORTH AMERICAN VERTICAL DATUM OF 1988 (12a) ADJUSTMENT (NAVD88)(12a). NO BUILDING OPENING TO BE CONSTRUCTED BELOW MINIMUM. LOTS 24-29 = 1052.75'. LOTS 30-33 = 1051.60'. LOT 34 = 1054.50'. LOT 49 = 1063.50'. LOT 50 = 1063.80'. LOTS 82-85 = 1056.00'. LOT 86 & 87 = 1058.25'. AND LOTS 89 & 90 = 1059.20'.
 16. BENCHMARKS IN NORTH AMERICAN VERTICAL DATUM OF 1988 (12a) ADJUSTMENT. (NAVD88)(12a)
BM-1 NE OF SECT. 30, TOP BRASS CAP = 1072.10' ON THIS SHEET
BM-2 CENTER OF SECT. 29, TOP BRASS CAP = 1047.63' ON SHEET 4 OF 6

There are no objections to this plat with respect to Secs. 236.15, 236.16, 236.20 and 236.21(1) and (2), Wis. Stats. as provided by s. 236.12, Wis. Stats.

Certified _____, 20____

Department of Administration

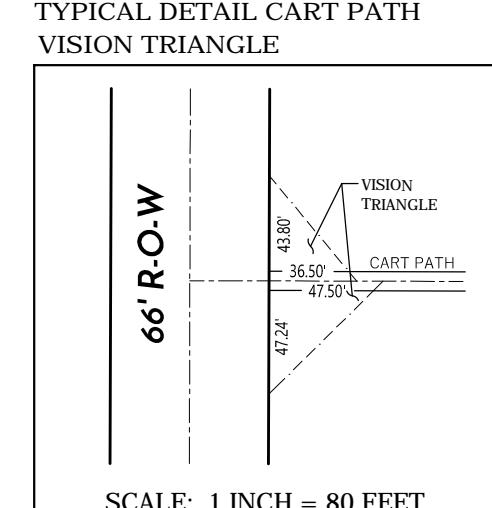
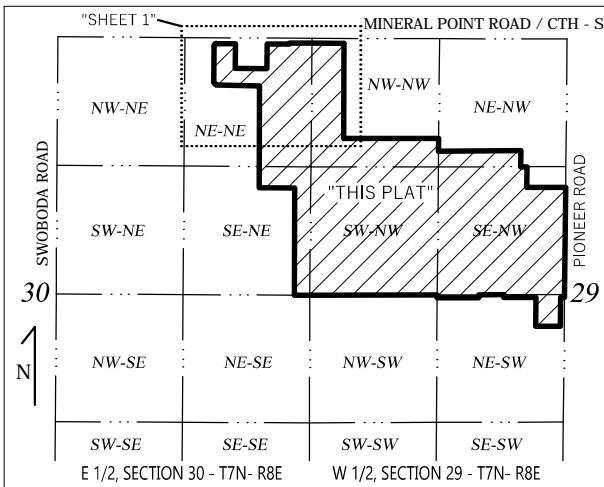
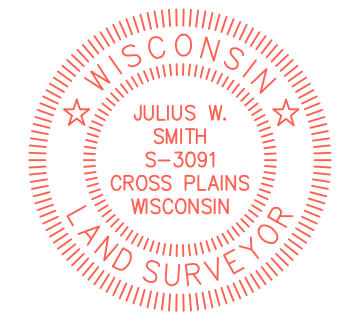

WYSER ENGINEERING
 SURVEYED BY:
 WYSER ENGINEERING
 312 EAST MAIN STREET
 MOUNT HOREB, WI 53572
 www.wyserengineering.com

PIONEER POINTE

ALL OF LOT 1 OF CERTIFIED SURVEY MAP NO. 6405 RECORDED IN VOLUME 31 ON PAGES 114-116 OF CERTIFIED SURVEY MAPS OF DANE COUNTY AS DOCUMENT NO. 2263455, LOT 1 OF CERTIFIED SURVEY MAP NO. 6406 RECORDED IN VOLUME 31 ON PAGES 117-119 OF CERTIFIED SURVEY MAPS OF DANE COUNTY AS DOCUMENT NO. 2263456, LOT 3 OF CERTIFIED SURVEY MAP NO. 14062 RECORDED IN VOLUME 94 ON PAGES 180-182 OF CERTIFIED SURVEY MAPS OF DANE COUNTY AS DOCUMENT NO. 5180509, LOT 1 OF CERTIFIED SURVEY MAP NO. 14753 RECORDED IN VOLUME 103 ON PAGES 39-42 OF CERTIFIED SURVEY MAPS OF DANE COUNTY AS DOCUMENT NO. 5398764, AND OTHER UNPLATTED LANDS BEING LOCATED IN THE NORTHWEST QUARTER OF THE NORTHWEST QUARTER, THE NORTHWEST QUARTER OF THE NORTHWEST QUARTER, THE SOUTHWEST QUARTER OF THE NORTHWEST QUARTER, THE SOUTHWEST QUARTER OF THE NORTHWEST QUARTER AND THE NORTHEAST QUARTER OF SECTION 29, AND THE NORTHEAST QUARTER OF THE NORTHEAST QUARTER AND SOUTHWEST QUARTER OF SECTION 30 ALL IN TOWN 7 NORTH, RANGE 8 EAST, TOWN OF MIDDLETON, DANE COUNTY, WISCONSIN

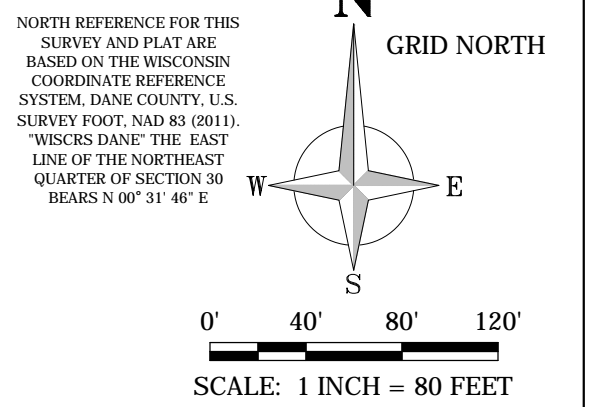

NORTHEAST CORNER SECTION 30-17N-R8E
FOUND BRASS CAP MONUMENT
N 477.591.67 (477.591.66) PER TOWN OF MIDDLETON
E 768.400.30 (768.400.31) REMONUMENTATION MAP

EAST 1/4 CORNER SECTION 30-17N-R8E
FOUND CITY OF MADISON ENGINEERING
BRASS CAP MONUMENT
N 474.914.99 (474.915.05) PER TOWN OF MIDDLETON
E 768.375.58 (768.375.56) REMONUMENTATION MAP

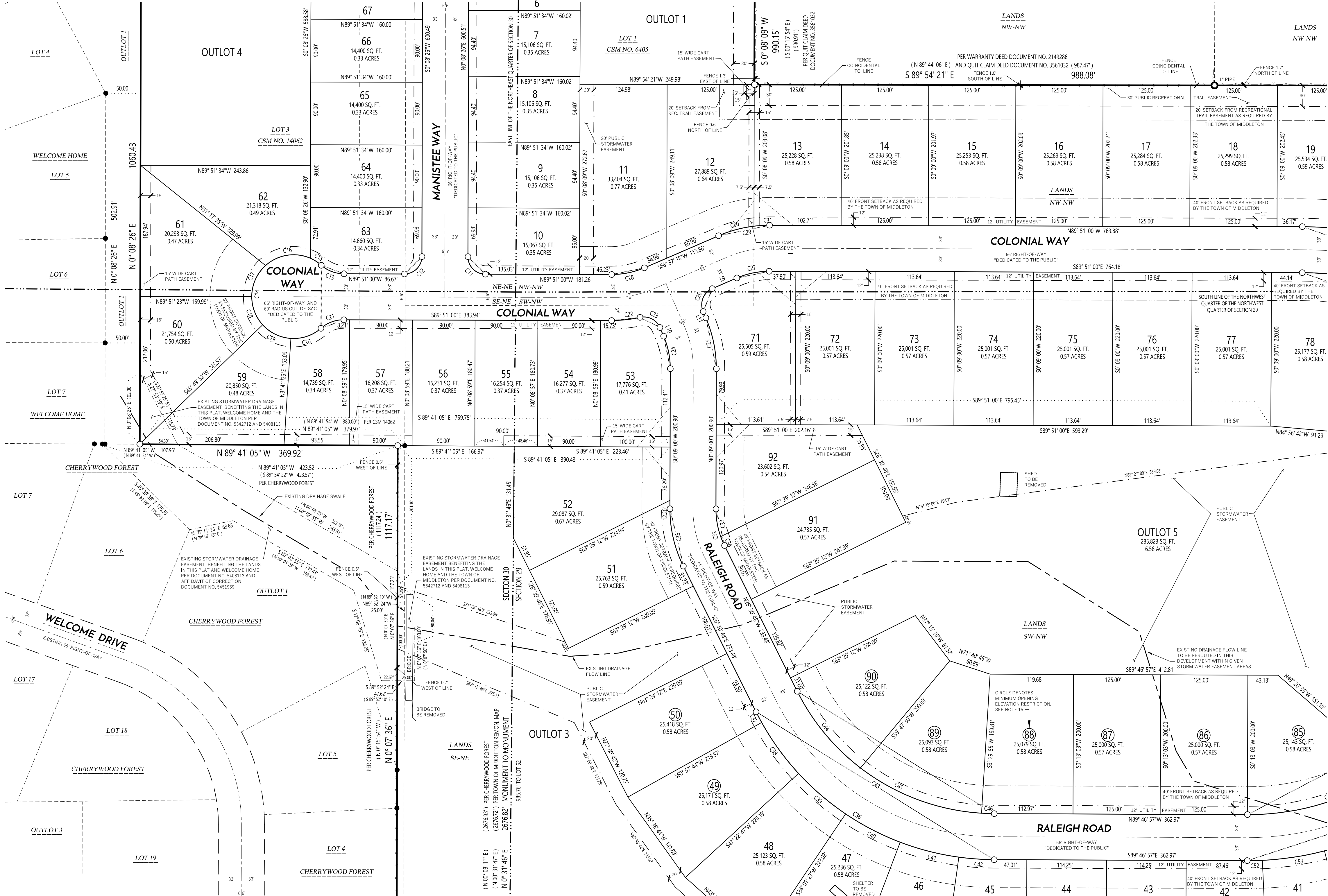

- LEGEND**
- FOUND PLSS SECTION MONUMENT TYPE NOTED
 - FOUND 3/4" REBAR
 - FOUND 1 1/4" REBAR
 - FOUND IRON PIPE, SIZE NOTED
 - FOUND PK NAIL
 - SET 1-1/4" X 18" REBAR 4.30 LBS./LIN. FT.
 - PLATTED BOUNDARY LINE
 - SECTION QUARTER LINE
 - CENTERLINE
 - CHORD LINE
 - - - - - EXISTING EASEMENT
 - - - - - EASEMENT LINE
 - - - - - EXISTING STRUCTURE
 - - - - - EXISTING DRAINAGE FLOWLINE/SWALE
 - - - - - EXISTING FENCE LINE
 - - - - - SETBACK WHERE REQUIRED BY THE TOWN
 - - - - - EXISTING SETBACK
 - - - - - VISION TRIANGLE RESTRICTION LINE
 - - - - - EXISTING WETLAND

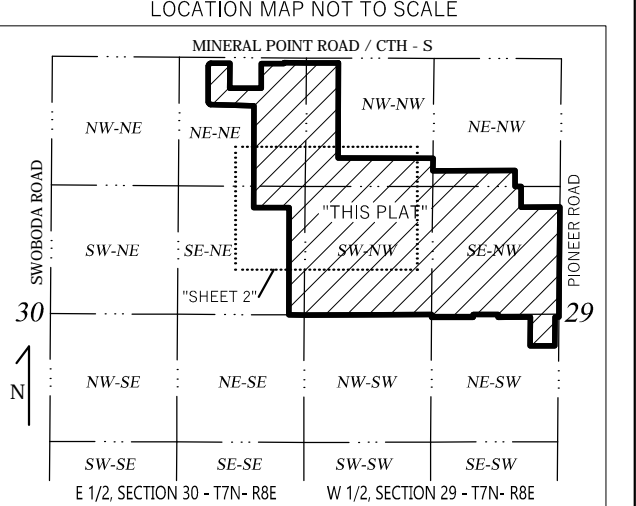

There are no objections to this plat with respect to Secs. 236.15, 236.16, 236.20 and 236.21(1) and (2), Wis. Stats. as provided by s. 236.12, Wis. Stats.

Certified _____, 20__

Department of Administration

WYSER ENGINEERING
SURVEYED BY:
WYSER ENGINEERING
312 EAST MAIN STREET
MOUNT HOREB, WI 53572
www.wyserengineering.com

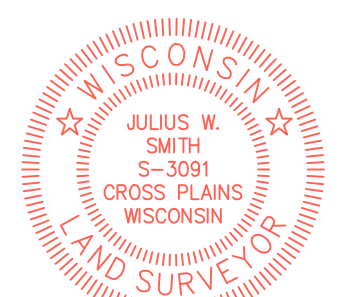

PIONEER POINTE

ALL OF LOT 1 OF CERTIFIED SURVEY MAP NO. 6405 RECORDED IN VOLUME 31 ON PAGES 114-116 OF CERTIFIED SURVEY MAPS OF DANE COUNTY AS DOCUMENT NO. 2263455, LOT 1 OF CERTIFIED SURVEY MAP NO. 6406 RECORDED IN VOLUME 31 ON PAGES 117-119 OF CERTIFIED SURVEY MAPS OF DANE COUNTY AS DOCUMENT NO. 2263456, LOT 3 OF CERTIFIED SURVEY MAP NO. 14062 RECORDED IN VOLUME 94 ON PAGES 180-182 OF CERTIFIED SURVEY MAPS OF DANE COUNTY AS DOCUMENT NO. 5180509, LOT 1 OF CERTIFIED SURVEY MAP NO. 14753 RECORDED IN VOLUME 103 ON PAGES 39-42 OF CERTIFIED SURVEY MAPS OF DANE COUNTY AS DOCUMENT NO. 5398764, AND OTHER UNPLATTED LANDS BEING LOCATED IN THE NORTHWEST QUARTER OF THE NORTHWEST QUARTER, THE NORTHWEST QUARTER OF THE NORTHWEST QUARTER, THE SOUTHWEST QUARTER OF THE NORTHWEST QUARTER, THE SOUTHWEST QUARTER OF THE NORTHWEST QUARTER AND THE NORTHWEST QUARTER OF SECTION 29, AND THE NORTHWEST QUARTER OF THE NORTHWEST QUARTER AND SOUTHWEST QUARTER OF SECTION 30 ALL IN TOWN 7 NORTH, RANGE 8 EAST, TOWN OF MIDDLETON, DANE COUNTY, WISCONSIN

NORTH 1/4 CORNER SECTION 29-T7N-R8E FOUND BRASS CAP
N: 477,585.72 (477,585.70) PER TOWN OF MIDDLETON
E: 771,055.95 (771,055.94) REMONUMENTATION MAP

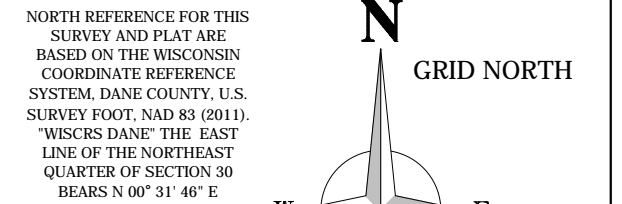

0' 40' 80' 120'
SCALE: 1 INCH = 80 FEET

LEGEND

- FOUND PLSS SECTION MONUMENT TYPE NOTED
- FOUND 3/4" REBAR
- FOUND 1-1/4" REBAR
- FOUND IRON PIPE, SIZE NOTED
- FOUND PK NAIL
- SET 1-1/4" X 18" REBAR 4.30 LIS./LIN. FT.
- (XXX) RECORDED AS
- PLATTED BOUNDARY LINE
- SECTION-QUARTER LINE
- RIGHT-OF-WAY LINE
- CENTERLINE
- CHORD LINE
- EXISTING EASEMENT
- EASEMENT LINE
- EXISTING STRUCTURE
- EXISTING DRAINAGE FLOWLINE/SWALE
- EXISTING FENCE LINE
- SETBACK WHERE REQUIRED BY THE TOWN
- EXISTING SETBACK
- VISION TRIANGLE RESTRICTION LINE
- EXISTING WETLAND

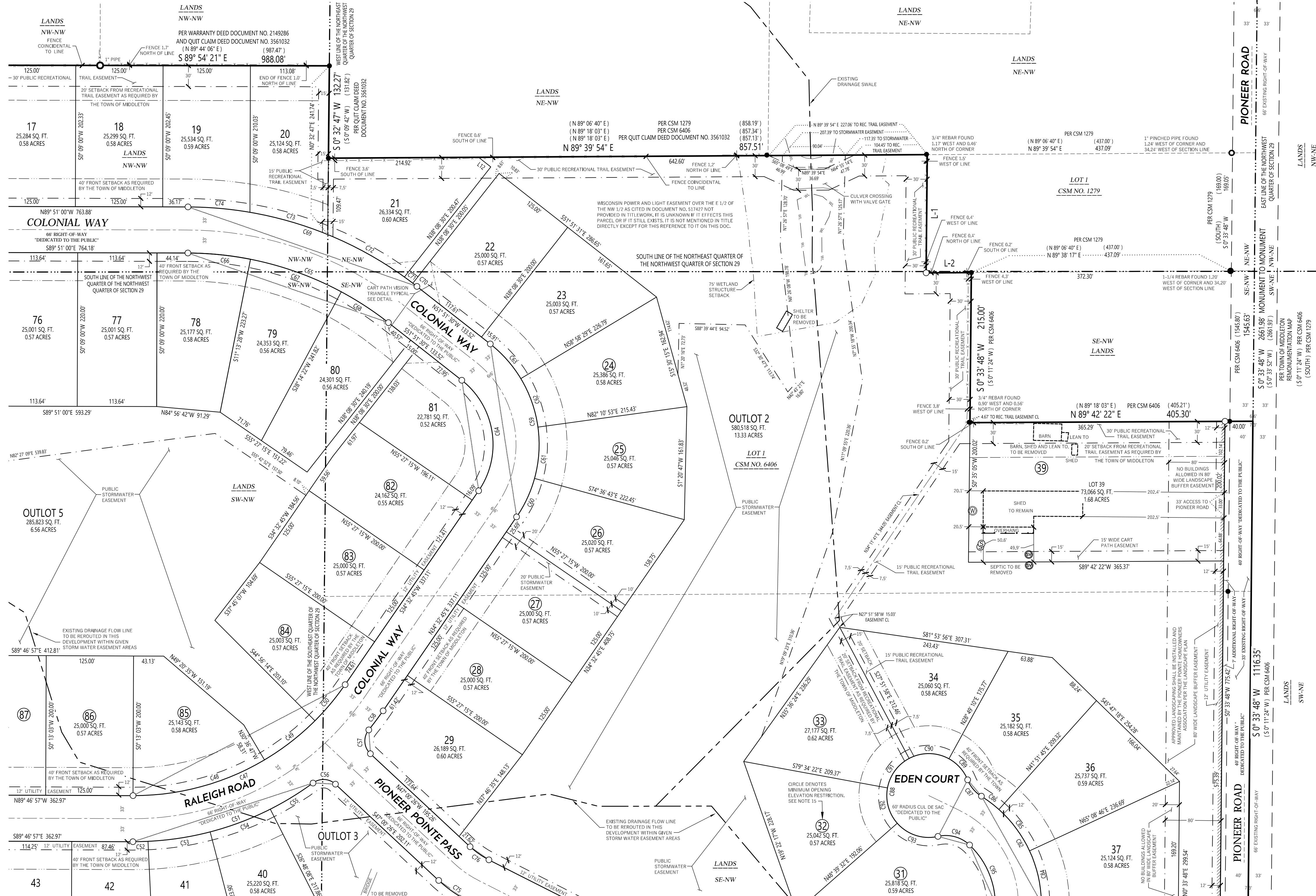

There are no objections to this plat with respect to Secs. 236.15, 236.16, 236.20 and 236.21(1) and (2), Wis. Stats. as provided by s. 236.12, Wis. Stats.

Certified _____, 20____

Department of Administration



WYSER ENGINEERING
SURVEYED BY:
WYSER ENGINEERING
312 EAST MAIN STREET
MOUNT HOREB, WI 53572
www.wyserengineering.com

CENTER OF SECTION 29-T7N-R8E
FOUND BRASS CAP MONUMENT
N: 474,923.87 (474,923.90) PER TOWN OF MIDDLETON
E: 771,029.77 (771,029.71) REMONUMENTATION MAP

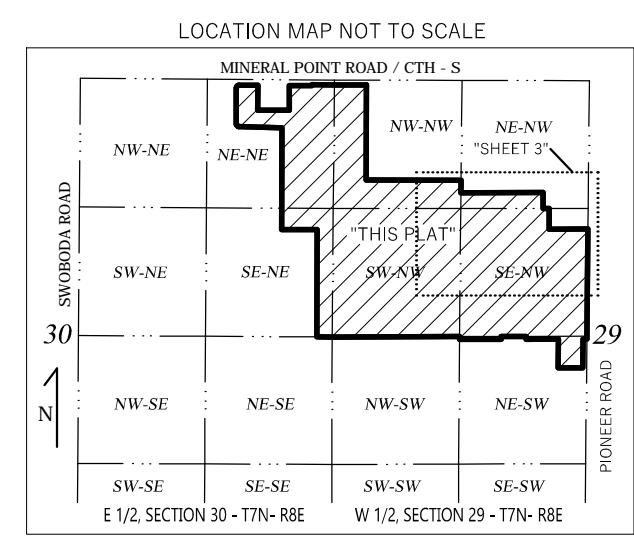

PIONEER POINTE

ALL OF LOT 1 OF CERTIFIED SURVEY MAP NO. 6405 RECORDED IN VOLUME 31 ON PAGES 114-116 OF CERTIFIED SURVEY MAPS OF DANE COUNTY AS DOCUMENT NO. 2263455, LOT 1 OF CERTIFIED SURVEY MAP NO. 6406 RECORDED IN VOLUME 31 ON PAGES 117-119 OF CERTIFIED SURVEY MAPS OF DANE COUNTY AS DOCUMENT NO. 2263456, LOT 3 OF CERTIFIED SURVEY MAP NO. 14062 RECORDED IN VOLUME 94 ON PAGES 180-182 OF CERTIFIED SURVEY MAPS OF DANE COUNTY AS DOCUMENT NO. 5180509, LOT 1 OF CERTIFIED SURVEY MAP NO. 14753 RECORDED IN VOLUME 103 ON PAGES 39-42 OF CERTIFIED SURVEY MAPS OF DANE COUNTY AS DOCUMENT NO. 5398764, AND OTHER UNPLATTED LANDS BEING LOCATED IN THE NORTHWEST QUARTER OF THE NORTHWEST QUARTER, THE NORTHEAST QUARTER OF THE NORTHWEST QUARTER, THE SOUTHWEST QUARTER OF THE NORTHWEST QUARTER AND THE SOUTHWEST QUARTER OF SECTION 29, AND THE NORTHEAST QUARTER OF THE NORTHWEST QUARTER AND SOUTHEAST QUARTER OF SECTION 30 ALL IN TOWN 7 NORTH, RANGE 8 EAST, TOWN OF MIDDLETON, DANE COUNTY, WISCONSIN

NORTH 1/4 CORNER SECTION 29-T7N-R8E FOUND BRASS CAP
N: 477,585.72 (477,585.70) PER TOWN OF MIDDLETON
E: 771,055.95 (771,055.94) REMONUMENTATION MAP

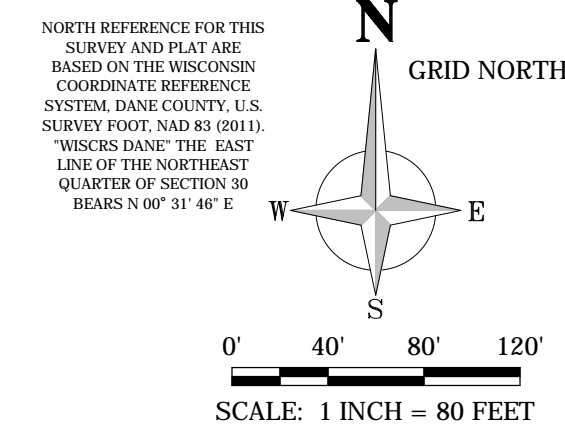

LEGEND

	FOUND PLSS SECTION MONUMENT TYPE NOTED
	FOUND 3/4" REBAR
	FOUND 1-1/4" REBAR
	FOUND IRON PIPE, SIZE NOTED
	FOUND PK NAIL
	SET 1-1/4" X 18" REBAR 430 LBS./LIN. FT.
	RECORDED AS
	PLATTED BOUNDARY LINE
	PLATTED LINE
	RIGHT-OF-WAY LINE
	CENTERLINE
	SECTION/QUARTER LINE
	CHORD LINE
	EXISTING EASEMENT
	EXISTING LINE
	EXISTING STRUCTURE
	EXISTING DRAINAGE FLOWLINE/SWALE
	EXISTING FENCE LINE
	SETBACK WHERE REQUIRED BY THE TOWN
	EXISTING SETBACK
	VISION TRIANGLE RESTRICTION LINE
	EXISTING WETLAND

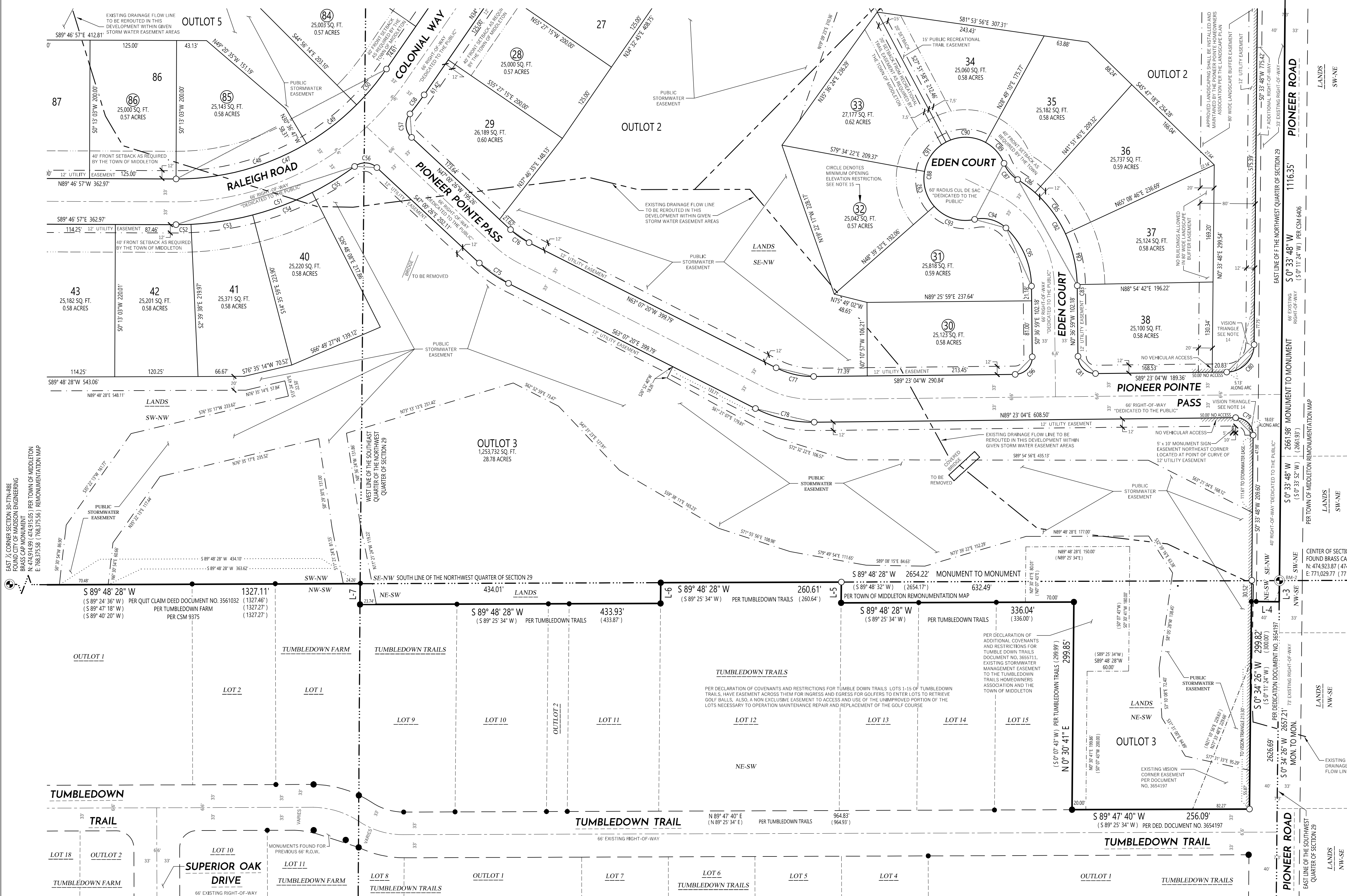

There are no objections to this plat with respect to Secs. 236.15, 236.16, 236.20 and 236.21(1) and (2), Wis. Stats. as provided by s. 236.12, Wis. Stats.

Certified _____, 20__

Department of Administration



WYSER ENGINEERING
SURVEYED BY:
WYSER ENGINEERING
312 EAST MAIN STREET
MOUNT HOREB, WI 53572
www.wyserengineering.com

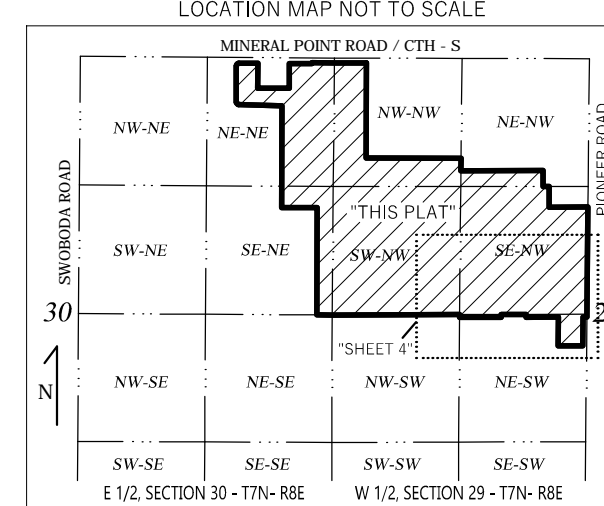

PIONEER POINTE

ALL OF LOT 1 OF CERTIFIED SURVEY MAP NO. 6405 RECORDED IN VOLUME 31 ON PAGES 114-116 OF CERTIFIED SURVEY MAPS OF DANE COUNTY AS DOCUMENT NO. 2263455, LOT 1 OF CERTIFIED SURVEY MAP NO. 6406 RECORDED IN VOLUME 31 ON PAGES 117-119 OF CERTIFIED SURVEY MAPS OF DANE COUNTY AS DOCUMENT NO. 2263456, LOT 3 OF CERTIFIED SURVEY MAP NO. 14062 RECORDED IN VOLUME 94 ON PAGES 180-182 OF CERTIFIED SURVEY MAPS OF DANE COUNTY AS DOCUMENT NO. 5180509, LOT 1 OF CERTIFIED SURVEY MAP NO. 14753 RECORDED IN VOLUME 103 ON PAGES 39-42 OF CERTIFIED SURVEY MAPS OF DANE COUNTY AS DOCUMENT NO. 5398764, AND OTHER UNPLATTED LANDS BEING LOCATED IN THE NORTHWEST QUARTER OF THE NORTHWEST QUARTER, THE NORTHEAST QUARTER OF THE NORTHWEST QUARTER, THE SOUTHWEST QUARTER OF THE NORTHWEST QUARTER, THE SOUTHWEST QUARTER OF THE NORTHWEST QUARTER AND THE NORTHEAST QUARTER OF SECTION 30 ALL IN TOWN 7 NORTH, RANGE 8 EAST, TOWN OF MIDDLETON, DANE COUNTY, WISCONSIN

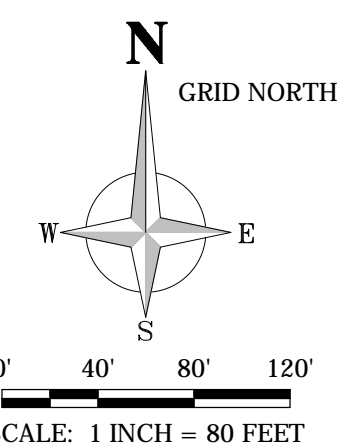

LEGEND

	FOUND PLSS SECTION MONUMENT TYPE NOTED
	FOUND 3/4" REBAR
	FOUND 1-1/4" REBAR
	FOUND IRON PIPE - SIZE NOTED
	FOUND PK NAIL
	SET 1-1/4" X 18" REBAR 4.30 LBS./LIN. FT.
	RECORDED AS
	PLAT BOUNDARY LINE
	PLATTED LINE
	RIGHT-OF-WAY LINE
	CENTERLINE
	SECTION/QUARTER LINE
	CHORD LINE
	EXISTING EASEMENT
	EASEMENT LINE
	EXISTING STRUCTURE
	EXISTING DRAINAGE FLOWLINE/SWALE
	EXISTING FENCE LINE
	SETBACK WHERE REQUIRED BY THE TOWN
	EXISTING SETBACK
	VISION TRIANGLE RESTRICTION LINE
	EXISTING WETLAND

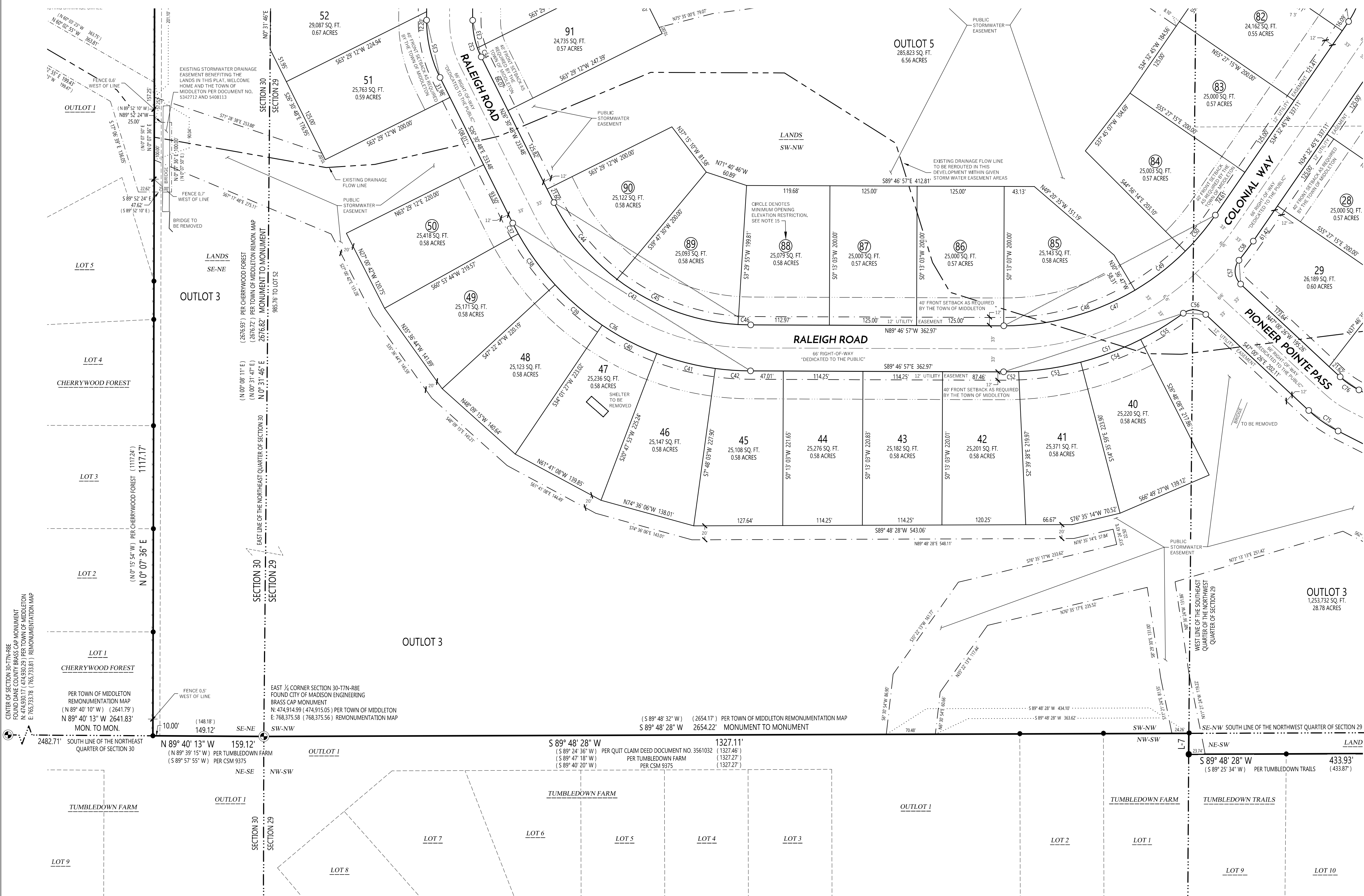

There are no objections to this plat with respect to Secs. 236.15, 236.16, 236.20 and 236.21(1) and (2), Wis. Stats. as provided by s. 236.12, Wis. Stats.

Certified _____, 20__

Department of Administration

WYSER ENGINEERING
 SURVEYED BY:
 WYSER ENGINEERING
 312 EAST MAIN STREET
 MOUNT HOREB, WI 53572
 www.wyserengineering.com

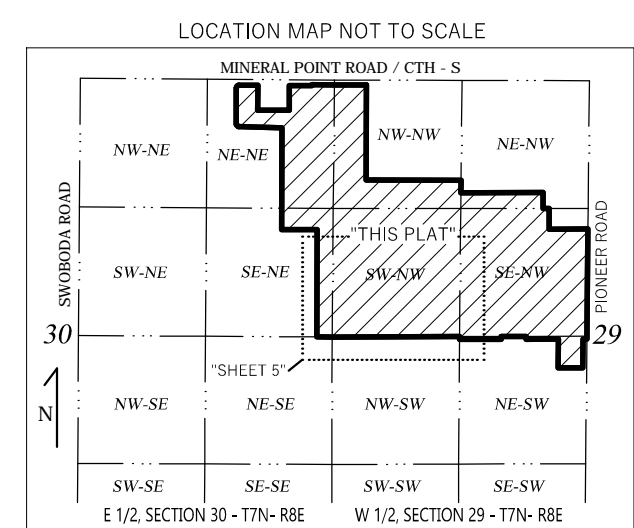

PIONEER POINTE

ALL OF LOT 1 OF CERTIFIED SURVEY MAP NO. 6405 RECORDED IN VOLUME 31 ON PAGES 114-116 OF CERTIFIED SURVEY MAPS OF DANE COUNTY AS DOCUMENT NO. 2263455, LOT 1 OF CERTIFIED SURVEY MAP NO. 6406 RECORDED IN VOLUME 31 ON PAGES 117-119 OF CERTIFIED SURVEY MAPS OF DANE COUNTY AS DOCUMENT NO. 2263456, LOT 3 OF CERTIFIED SURVEY MAP NO. 14062 RECORDED IN VOLUME 94 ON PAGES 180-182 OF CERTIFIED SURVEY MAPS OF DANE COUNTY AS DOCUMENT NO. 5180509, LOT 1 OF CERTIFIED SURVEY MAP NO. 14753 RECORDED IN VOLUME 103 ON PAGES 39-42 OF CERTIFIED SURVEY MAPS OF DANE COUNTY AS DOCUMENT NO. 5398764, AND OTHER UNPLATTED LANDS BEING LOCATED IN THE NORTHWEST QUARTER OF THE NORTHWEST QUARTER, THE NORTHEAST QUARTER OF THE NORTHWEST QUARTER, THE SOUTHWEST QUARTER OF THE NORTHWEST QUARTER, THE SOUTHEAST QUARTER OF THE NORTHWEST QUARTER AND THE NORTHEAST QUARTER OF SECTION 29, AND THE NORTHEAST QUARTER OF THE NORTHWEST QUARTER AND SOUTHEAST QUARTER OF THE NORTHWEST QUARTER OF SECTION 30 ALL IN TOWN 7 NORTH, RANGE 8 EAST, TOWN OF MIDDLETON, DANE COUNTY, WISCONSIN

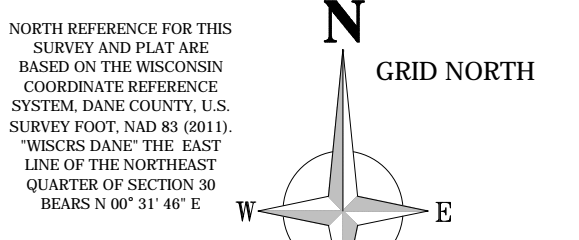

0' 100' 200' 300'
SCALE: 1 INCH = 200 FEET

OVERVIEW SHEET OF ENTIRE PLAT

EXISTING LANDSCAPING PONDS SHOWN TO FULFILL WIS STATE STATS. 236.20(5)(b)

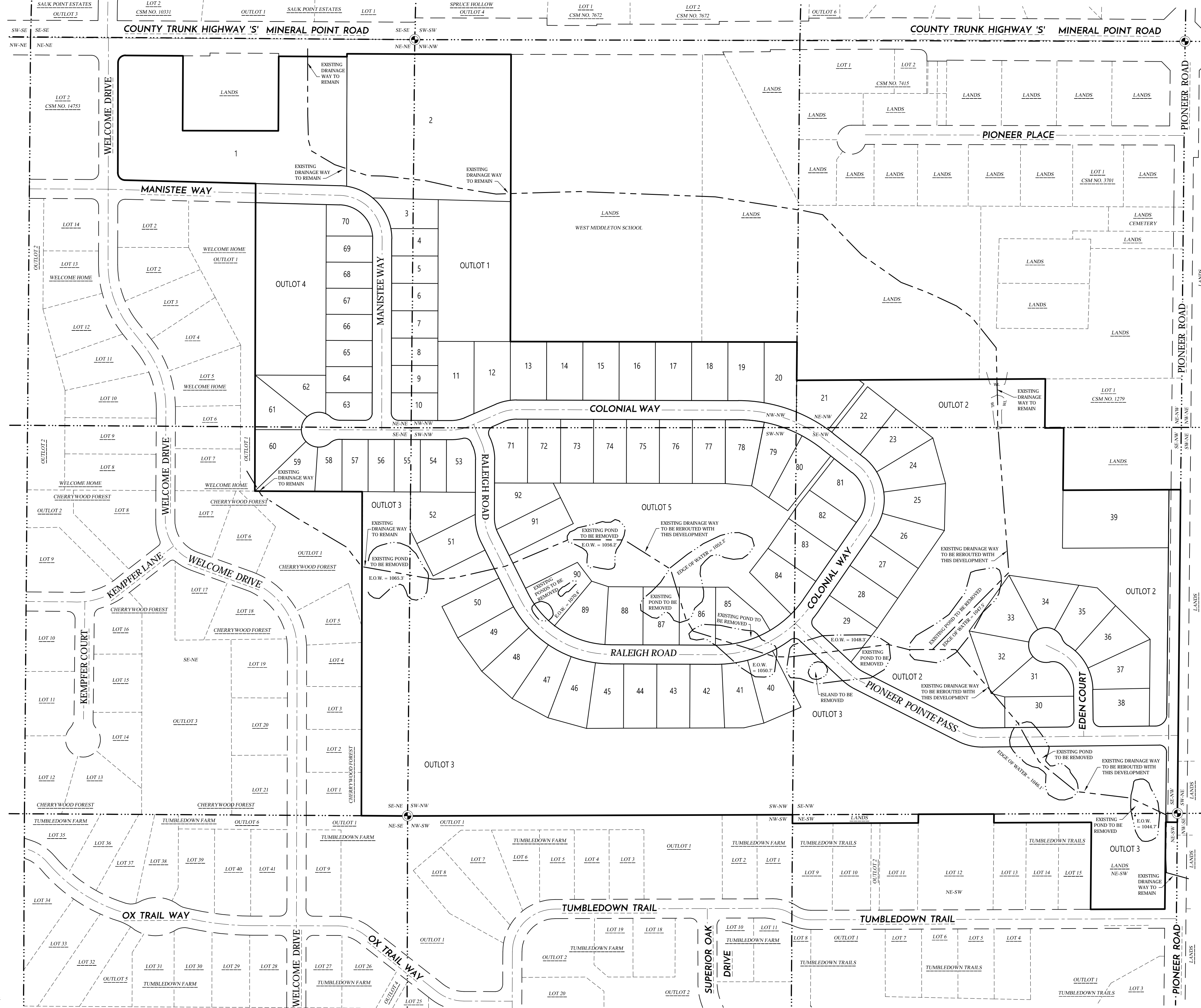

- ### LEGEND
- FOUND PLSS SECTION MONUMENT TYPE NOTED
 - (E.O.W.) EDGE OF WATER
 - PLATTED LINE
 - RIGHT-OF-WAY LINE
 - CENTERLINE
 - SECTION/QUARTER LINE
 - EXISTING LANDSCAPE POND EDGE OF WATER
 - EXISTING DRAINAGE FLOWLINE/SWALE
 - EXISTING WETLAND

- ### NOTES
- AS DERIVED FROM SHEET 1 OF 7
13. PLAT CONTAINS EXISTING POND FEATURES AND WHICH ARE PRIVATE LANDSCAPED WATER FEATURES FOR THE CURRENT TUMBLEDOWN GOLF COURSE AND ARE SHOWN ON SHEET 6 OF 7. THE EDGE OF WATER LOCATIONS AND ELEVATIONS WERE DETERMINED FROM THE TOP OF ICE AS LOCATED ON FEBRUARY 14, 2019 ALL LANDSCAPE PONDS AS SHOWN ON SHEET 6 OF 7 WILL BE FILLED/REMOVED.
 16. BENCHMARKS IN NORTH AMERICAN VERTICAL DATUM OF 1988 (12a) ADJUSTMENT. (NAV88)(12a)
BM-1 NE OF SECT. 30, TOP BRASS CAP = 1072.10' ON THIS SHEET
BM-2 CENTER OF SECT. 29, TOP BRASS CAP = 1047.63' ON SHEET 4 OF 6

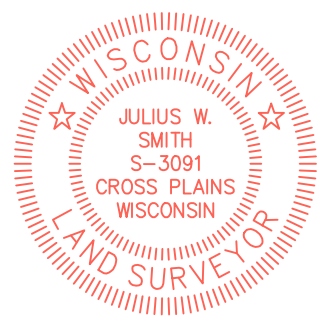

WYSER ENGINEERING
SURVEYED BY:
WYSER ENGINEERING
312 EAST MAIN STREET
MOUNT HOREB, WI 53572
www.wyserengineering.com

There are no objections to this plat with respect to Secs. 236.15, 236.16, 236.20 and 236.21(1) and (2), Wis. Stats. as provided by s. 236.12, Wis. Stats.
Certified _____, 20____
Department of Administration

PIONEER POINTE

LINE TABLE					
LINE #	BEARING	LENGTH	LINE #	BEARING	LENGTH
L-1	S 0° 33' 48" W	169.26	L-6 (****)	(S 0° 07' 43" W)	
(*)	(S 0° 11' 23" W)	(169.00)	L-7	N 0° 21' 10" E	30.00
(**)	(SOUTH)	(169.00)	(****)	(N 0° 02' 28" W)	
L-2	N 89° 38' 17" E	64.79	(****)	(N 0° 20' 41" E)	
(*)	(N 89° 18' 03" E)		(****)	(N 0° 03' 31" E)	
L-3	S 0° 34' 26" W	30.52	L-8	N 0° 08' 09" E	10.00
L-4	N 89° 25' 34" W	40.00	(*****)	(N 0° 08' 26" E)	
(***)	(N 89° 48' 36" W)		L-9	N 66° 37' 18" E	38.42
L-5	N 0° 30' 41" E	30.00	L-10	S 23° 22' 42" E	13.47
(****)	(N 0° 07' 43" E)		L-11	N 23° 22' 42" W	9.87
L-6	S 0° 30' 41" W	30.00	L-12	N 51° 51' 31" W	22.39

* PER CSM 6406 ** PER CSM 1279 *** PER DEDICATION FOR TOWN ROAD DOCUMENT NO. 3654197
**** PER TUMBLEDOWN TRAILS ***** PER TUMBLEDOWN FARM ***** PER CSM 9375 ***** PER CSM 14753

ALL OF LOT 1 OF CERTIFIED SURVEY MAP NO. 6405 RECORDED IN VOLUME 31 ON PAGES 114-116 OF CERTIFIED SURVEY MAPS OF DANE COUNTY AS DOCUMENT NO. 2263455, LOT 1 OF CERTIFIED SURVEY MAP NO. 6406 RECORDED IN VOLUME 31 ON PAGES 117-119 OF CERTIFIED SURVEY MAPS OF DANE COUNTY AS DOCUMENT NO. 2263456, LOT 3 OF CERTIFIED SURVEY MAP NO. 14062 RECORDED IN VOLUME 94 ON PAGES 180-182 OF CERTIFIED SURVEY MAPS OF DANE COUNTY AS DOCUMENT NO. 5180509, LOT 1 OF CERTIFIED SURVEY MAP NO. 14753 RECORDED IN VOLUME 103 ON PAGES 39-42 OF CERTIFIED SURVEY MAPS OF DANE COUNTY AS DOCUMENT NO. 5398764, AND OTHER UNPLATTED LANDS BEING LOCATED IN THE NORTHWEST QUARTER OF THE NORTHWEST QUARTER, THE NORTHEAST QUARTER OF THE NORTHWEST QUARTER, THE SOUTHWEST QUARTER OF THE NORTHWEST QUARTER, THE SOUTHWEST QUARTER OF THE NORTHWEST QUARTER AND THE NORTHEAST QUARTER OF THE NORTHWEST QUARTER OF SECTION 29, AND THE NORTHEAST QUARTER OF THE NORTHEAST QUARTER AND SOUTHEAST QUARTER OF THE NORTHEAST QUARTER OF SECTION 30 ALL IN TOWN 7 NORTH, RANGE 8 EAST, TOWN OF MIDDLETON, DANE COUNTY, WISCONSIN

CERTIFICATE OF TOWN TREASURER

STATE OF WISCONSIN
DANE COUNTY) ss.

I, GREG DIMICELI, BEING THE DULY APPOINTED, QUALIFIED AND ACTING TREASURER OF THE TOWN OF MIDDLETON, DO HEREBY CERTIFY THAT IN ACCORDANCE WITH THE RECORDS IN MY OFFICE, THERE ARE NO UNPAID TAXES OR UNPAID SPECIAL ASSESSMENTS AS OF _____

THIS _____ DAY OF _____, 20___ ON ANY OF THE LANDS INCLUDED IN THE PLAT OF PIONEER POINTE.

DATE _____ GREG DIMICELI, TREASURER, TOWN OF MIDDLETON

CERTIFICATE OF COUNTY TREASURER

STATE OF WISCONSIN
DANE COUNTY) ss.

I, ADAM GALLAGHER, BEING THE DULY ELECTED, QUALIFIED AND ACTING TREASURER OF DANE COUNTY, DO HEREBY CERTIFY THAT IN ACCORDANCE WITH THE RECORDS IN MY OFFICE, THERE ARE NO UNREDEEMED TAX SALES AND NO UNPAID TAXES OR SPECIAL ASSESSMENTS AS OF _____

THIS _____ DAY OF _____, 20___ AFFECTING THE LANDS INCLUDED IN THE PLAT OF PIONEER POINTE.

DATE _____ ADAM GALLAGHER, DANE COUNTY TREASURER

CERTIFICATE OF TOWN BOARD APPROVAL

STATE OF WISCONSIN
DANE COUNTY) ss.

"RESOLVED THAT THIS PLAT KNOWN AS PIONEER POINTE WHICH HAS BEEN DULY FILED FOR THE APPROVAL OF THE TOWN OF MIDDLETON, DANE COUNTY, WISCONSIN, BE, AND THE SAME IS HEREBY APPROVED AS REQUIRED BY CHAPTER 236, OF WISCONSIN STATUTES."

I HEREBY CERTIFY THAT THE ABOVE IS A TRUE AND CORRECT COPY OF A RESOLUTION ADOPTED BY THE TOWN BOARD OF THE TOWN OF MIDDLETON, AND THAT SAID RESOLUTION FURTHER PROVIDED FOR THE ACCEPTANCE OF THOSE LANDS AND RIGHTS DEDICATED BY SAID PIONEER POINTE FOR PUBLIC USE.

ON THIS _____ DAY OF _____, 20___

DATE _____ BARBARA ROESSLEIN, CLERK, TOWN OF MIDDLETON

CERTIFICATE OF DANE COUNTY ZONING AND LAND REGULATION COMMITTEE APPROVAL

RESOLVED, THAT THE PLAT OF PIONEER POINTE IN THE TOWN OF MIDDLETON, DANE COUNTY, WISCONSIN, IS HEREBY APPROVED BY THE DANE COUNTY ZONING AND LAND REGULATION COMMITTEE.

ON THIS _____ DAY OF _____, 20___

MARY KOLAR, CHAIR DANE COUNTY ZONING AND LAND REGULATION COMMITTEE

CONSENT OF MORTGAGEE

XXXXXX BANK, A NATIONAL BANKING ASSOCIATION, MORTGAGEE OF THE ABOVE DESCRIBED LAND, DOES HEREBY CONSENT TO THE SURVEY, DIVIDING, MAPPING AND DEDICATION OF THE LAND DESCRIBED ON THIS PLAT AND DOES HEREBY CONSENT TO THE OWNER'S CERTIFICATE.

IN WITNESS WHEREOF, SAID XXXXXXXX BANK HAS CAUSED THESE PRESENTS TO BE SIGNED BY CORPORATE OFFICER, AND ITS CORPORATE SEAL TO BE HEREUNTO AFFIXED

ON THIS _____ DAY OF _____, 20___

BY: _____ AUTHORIZED OFFICER

STATE OF WISCONSIN
DANE COUNTY) ss.

PERSONALLY CAME BEFORE ME THIS _____ DAY OF _____, 20___

THE ABOVE NAMED BANKING ASSOCIATION, XXXXXXXX BANK

AUTHORIZED OFFICER _____ TO ME KNOWN TO BE THE PERSON WHO EXECUTED THE FOREGOING INSTRUMENT, AND ACKNOWLEDGED THE SAME.

NOTARY PUBLIC, STATE OF WISCONSIN _____ MY COMMISSION EXPIRES _____

OWNER'S CERTIFICATE OF DEDICATION

JEKY LLC, AS OWNER, WE HEREBY CERTIFY THAT WE CAUSED THE LAND DESCRIBED ON THIS PLAT TO BE SURVEYED, DIVIDED, MAPPED AND DEDICATED AS REPRESENTED ON THE PLAT. WE ALSO CERTIFY THAT THIS PLAT IS REQUIRED BY S.236.10 OR S.236.12 TO BE SUBMITTED TO THE FOLLOWING FOR APPROVAL OR OBJECTION:

DEPARTMENT OF ADMINISTRATION
TOWN OF MIDDLETON
DANE COUNTY ZONING AND NATURAL RESOURCES COMMITTEE

WITNESS THE HAND AND SEAL OF SAID OWNER THIS _____ DAY OF _____, 20___ IN PRESENCE OF:

JEKY LLC
BY: MANAGING MEMBER _____

STATE OF WISCONSIN
DANE COUNTY) ss.

PERSONALLY CAME BEFORE ME THIS _____ DAY OF _____, 20___

THE ABOVE NAMED _____ MANAGING MEMBER FOR JEKY LLC TO ME KNOWN TO BE THE SAME PERSON WHO EXECUTED THE FOREGOING INSTRUMENT AND ACKNOWLEDGED THE SAME.

THIS _____ DAY OF _____, 20___ AFFECTING THE LANDS INCLUDED IN THE PLAT OF PIONEER POINTE.

NOTARY PUBLIC, STATE OF WISCONSIN _____

MY COMMISSION EXPIRES _____

CONSENT OF MORTGAGEE

XXXXXX BANK, A NATIONAL BANKING ASSOCIATION, MORTGAGEE OF THE ABOVE DESCRIBED LAND, DOES HEREBY CONSENT TO THE SURVEY, DIVIDING, MAPPING AND DEDICATION OF THE LAND DESCRIBED ON THIS PLAT AND DOES HEREBY CONSENT TO THE OWNER'S CERTIFICATE.

IN WITNESS WHEREOF, SAID XXXXXXXX BANK HAS CAUSED THESE PRESENTS TO BE SIGNED BY CORPORATE OFFICER, AND ITS CORPORATE SEAL TO BE HEREUNTO AFFIXED

ON THIS _____ DAY OF _____, 20___

BY: _____ AUTHORIZED OFFICER

STATE OF WISCONSIN
DANE COUNTY) ss.

PERSONALLY CAME BEFORE ME THIS _____ DAY OF _____, 20___

THE ABOVE NAMED BANKING ASSOCIATION, XXXXXXXX BANK

AUTHORIZED OFFICER _____ TO ME KNOWN TO BE THE PERSON WHO EXECUTED THE FOREGOING INSTRUMENT, AND ACKNOWLEDGED THE SAME.

NOTARY PUBLIC, STATE OF WISCONSIN _____ MY COMMISSION EXPIRES _____

OWNER'S CERTIFICATE OF DEDICATION

WATTS FAMILY TRUST, AS OWNER, WE HEREBY CERTIFY THAT WE CAUSED THE LAND DESCRIBED ON THIS PLAT TO BE SURVEYED, DIVIDED, MAPPED AND DEDICATED AS REPRESENTED ON THE PLAT. WE ALSO CERTIFY THAT THIS PLAT IS REQUIRED BY S.236.10 OR S.236.12 TO BE SUBMITTED TO THE FOLLOWING FOR APPROVAL OR OBJECTION:

DEPARTMENT OF ADMINISTRATION
TOWN OF MIDDLETON
DANE COUNTY ZONING AND NATURAL RESOURCES COMMITTEE

WITNESS THE HAND AND SEAL OF SAID OWNER THIS _____ DAY OF _____, 20___ IN PRESENCE OF:

WATTS FAMILY TRUST
BY: TRUSTEE _____

STATE OF WISCONSIN
DANE COUNTY) ss.

PERSONALLY CAME BEFORE ME THIS _____ DAY OF _____, 20___

THE ABOVE NAMED _____ TRUSTEE FOR WATTS FAMILY TRUST TO ME KNOWN TO BE THE SAME PERSON WHO EXECUTED THE FOREGOING INSTRUMENT AND ACKNOWLEDGED THE SAME.

NOTARY PUBLIC, STATE OF WISCONSIN _____

MY COMMISSION EXPIRES _____

SURVEYOR'S CERTIFICATE

I, JULIUS W. SMITH, PROFESSIONAL LAND SURVEYOR, HEREBY CERTIFY: THAT IN FULL COMPLIANCE WITH THE PROVISIONS OF CHAPTER 236 OF THE WISCONSIN STATUTES, AND PROVISIONS AS STATED IN CHAPTER 315, LAND DIVISION AND SUBDIVISION - TOWN OF MIDDLETON ORDINANCES AND UNDER THE PROVISIONS OF HARBOR AND CANAL ACTS, I HAVE SURVEYED, DIVIDED AND MAPPED PIONEER POINTE, THAT SUCH PLAT CORRECTLY REPRESENTS ALL EXTERIOR BOUNDARIES AND THE SUBDIVISION OF THE LAND SURVEYED; AND THAT THIS LAND IS LOCATED IN THE NW-1/4 OF THE NW-1/4, NE-1/4 OF THE NW-1/4, SW-1/4 OF THE NW-1/4, SE-1/4 OF THE NW-1/4 AND THE NE-1/4 OF THE SW-1/4 OF SECTION 29, AND THE NE-1/4 OF THE NE-1/4 AND SE-1/4 OF THE NE-1/4 OF SECTION 30 ALL IN T7N, R8E, TOWN OF MIDDLETON, DANE COUNTY, WISCONSIN, CONTAINING 127.42 ACRES OF LAND AND DESCRIBED AS FOLLOWS:

ALL OF LOT 1 OF CERTIFIED SURVEY MAP NO. 6405 (CSM 6405) RECORDED IN VOLUME 31 ON PAGES 114-116 OF CERTIFIED SURVEY MAPS OF DANE COUNTY AS DOCUMENT NO. 2263455, LOT 1 OF CERTIFIED SURVEY MAP NO. 6406 (CSM 6406) RECORDED IN VOLUME 31 ON PAGES 117-119 OF CERTIFIED SURVEY MAPS OF DANE COUNTY AS DOCUMENT NO. 2263456, LOT 3 OF CERTIFIED SURVEY MAP NO. 14062 (CSM 14062) RECORDED IN VOLUME 94 ON PAGES 180-182 OF CERTIFIED SURVEY MAPS OF DANE COUNTY AS DOCUMENT NO. 5180509, LOT 1 OF CERTIFIED SURVEY MAP NO. 14753 (CSM 14753) RECORDED IN VOLUME 103 ON PAGES 39-42 OF CERTIFIED SURVEY MAPS OF DANE COUNTY AS DOCUMENT NO. 5398764, AND OTHER UNPLATTED LANDS BEING LOCATED IN THE NORTHWEST QUARTER OF THE NORTHWEST QUARTER, THE NORTHEAST QUARTER OF THE NORTHWEST QUARTER, THE SOUTHWEST QUARTER OF THE NORTHWEST QUARTER, THE SOUTHWEST QUARTER OF THE NORTHWEST QUARTER, THE SOUTHWEST QUARTER OF THE NORTHWEST QUARTER AND THE NORTHEAST QUARTER OF THE NORTHWEST QUARTER OF SECTION 29, AND THE NORTHEAST QUARTER OF THE NORTHEAST QUARTER AND SOUTHEAST QUARTER OF THE NORTHEAST QUARTER OF SECTION 30 ALL IN TOWN 7 NORTH, RANGE 8 EAST, TOWN OF MIDDLETON, DANE COUNTY, WISCONSIN, BEING MORE FULLY DESCRIBED AS FOLLOWS:

COMMENCING AT THE NORTHWEST CORNER OF AFORESAID SECTION 29; THENCE SOUTH 00 DEGREES 12 MINUTES 15 SECONDS WEST, 50.00 FEET TO THE SOUTHERLY RIGHT-OF-WAY LINE OF MINERAL POINT ROAD, ALSO KNOWN AS BEING COUNTY TRUNK HIGHWAY S RIGHT-OF-WAY AND THE POINT OF BEGINNING;

THENCE ALONG SAID RIGHT-OF-WAY OF MINERAL POINT ROAD SOUTH 89 DEGREES 32 MINUTES 17 SECONDS EAST, 332.35 FEET TO THE EAST LINE OF AFORESAID CSM 6405; THENCE ALONG SAID EAST LINE OF CSM 6405 SOUTH 00 DEGREES 08 MINUTES 09 SECONDS WEST, 990.15 FEET; THENCE SOUTH 89 DEGREES 54 MINUTES 21 SECONDS WEST, 989.88 FEET TO THE WEST LINE OF THE NORTHWEST QUARTER OF THE NORTHWEST QUARTER OF SAID SECTION 29; THENCE ALONG SAID WEST QUARTER-QUARTER LINE SOUTH 00 DEGREES 32 MINUTES 47 SECONDS WEST, 132.27 FEET TO THE NORTH LINE OF CSM 6406; THENCE ALONG SAID NORTH LINE OF CSM 6406 NORTH 89 DEGREES 39 MINUTES 54 SECONDS EAST, 857.51 FEET TO THE WEST LINE OF LOT 1 OF CERTIFIED SURVEY MAP NO. 1279 (CSM 1279) RECORDED IN VOLUME 5 ON PAGE 212 OF CERTIFIED SURVEY MAPS OF DANE COUNTY; THENCE ALONG SAID WEST LINE OF LOT 1 OF CSM 1279 SOUTH 00 DEGREES 33 MINUTES 48 SECONDS WEST, 169.20 FEET TO THE SOUTH LINE OF SAID CSM 1279; THENCE ALONG SAID SOUTH LINE OF CSM 1279 NORTH 89 DEGREES 38 MINUTES 17 SECONDS EAST, 64.79 FEET TO A LINE ALONG THE ON THE WESTERN BOUNDARY OF AFORESAID CSM 6406; THENCE ALONG SAID BOUNDARY OF SAID CSM 6406 SOUTH 00 DEGREES 33 MINUTES 48 SECONDS WEST, 215.00 FEET; THENCE CONTINUING ALONG SAID BOUNDARY OF CSM 6406 NORTH 89 DEGREES 42 MINUTES 22 SECONDS EAST, 405.30 FEET TO THE EAST LINE OF THE NORTHWEST QUARTER OF AFORESAID SECTION 29; THENCE ALONG SAID EAST LINE OF THE NORTHWEST QUARTER OF SECTION 29 SOUTH 00 DEGREES 33 MINUTES 48 SECONDS WEST, 1116.35 FEET TO THE MONUMENTED CENTER OF SAID SECTION 29; THENCE ALONG THE EAST LINE OF THE SOUTHWEST QUARTER OF SAID SECTION 29 SOUTH 00 DEGREES 26 SECONDS WEST, 30.52 FEET; THENCE NORTH 89 DEGREES 25 MINUTES 34 SECONDS WEST, 40.00 FEET TO THE WESTERLY RIGHT-OF-WAY LINE OF PIONEER ROAD; THENCE ALONG SAID WESTERLY RIGHT-OF-WAY LINE OF PIONEER ROAD SOUTH 00 DEGREES 34 MINUTES 26 SECONDS WEST, 299.82 FEET TO THE NORTHERLY RIGHT-OF-WAY LINE OF TUMBLEDOWN TRAIL; THENCE ALONG SAID NORTHERLY RIGHT-OF-WAY LINE OF TUMBLEDOWN TRAIL SOUTH 89 DEGREES 47 MINUTES 40 SECONDS WEST, 256.09 FEET TO THE EAST LINE OF LOT 15 OF TUMBLEDOWN TRAILS RECORDED IN VOLUME 58-013A OF PLATS OF DANE COUNTY ON PAGES 69 & 70 AS DOCUMENT NO. 3861598; THENCE ALONG THE EAST LINE OF LOT 15 OF TUMBLEDOWN TRAILS SOUTH 00 DEGREES 30 MINUTES 41 SECONDS EAST, 299.85 FEET TO THE NORTH LINE OF SAID LOT 15; THENCE ALONG SAID NORTH LINE OF LOT 15 AND CONTINUING SOUTH 89 DEGREES 48 MINUTES 28 SECONDS WEST, 366.04 FEET TO THE EAST LINE OF LOT 12 OF SAID TUMBLEDOWN TRAILS; THENCE ALONG SAID EAST LINE OF LOT 12 NORTH 00 DEGREES 30 MINUTES 41 SECONDS EAST, 30.00 FEET TO THE SOUTH LINE OF THE NORTHWEST QUARTER OF AFORESAID SECTION 29 ALSO BEING THE NORTH LINE OF SAID LOT 12; THENCE ALONG SAID SOUTH LINE OF THE NORTHWEST QUARTER OF SECTION 29 SOUTH 00 DEGREES 48 MINUTES 28 SECONDS WEST, 280.61 FEET TO THE WEST LINE OF SAID LOT 12 OF TUMBLEDOWN TRAILS; THENCE ALONG SAID WEST LINE OF LOT 12 SOUTH 00 DEGREES 30 MINUTES 41 SECONDS WEST, 30.00 FEET TO THE NORTH LINE OF LOT 11 OF SAID TUMBLEDOWN TRAILS; THENCE ALONG SAID NORTH LINE OF LOT 11 AND CONTINUING SOUTH 89 DEGREES 48 MINUTES 28 SECONDS WEST, 433.88 FEET TO THE EAST LINE OF LOT 1 OF TUMBLEDOWN FARM RECORDED IN VOLUME 60-088A OF PLATS OF DANE COUNTY ON PAGES 487-491 AS DOCUMENT NO. 3886818; THENCE ALONG SAID EAST LINE OF LOT 1 OF TUMBLEDOWN FARM NORTH 00 DEGREES 21 MINUTES 10 SECONDS EAST, 30.00 FEET TO THE NORTH LINE OF SAID LOT 1 ALSO BEING THE AFORESAID SOUTH LINE OF THE NORTHWEST QUARTER OF SECTION 29; THENCE ALONG SOUTH LINE OF THE NORTHWEST QUARTER OF SECTION 29 SOUTH 89 DEGREES 48 MINUTES 28 SECONDS EAST, 1327.11 FEET TO THE EAST QUARTER CORNER OF AFORESAID SECTION 30; THENCE ALONG THE SOUTH LINE OF SAID SECTION 30 NORTH 89 DEGREES 40 DEGREES 40 MINUTES 13 SECONDS WEST, 159.12 FEET TO THE EAST LINE OF CHERYWOOD FOREST RECORDED IN VOLUME 60-020A OF PLATS OF DANE COUNTY ON PAGES 100-101 AS DOCUMENT NO. 5027486; THENCE ALONG SAID EAST LINE OF CHERYWOOD FOREST NORTH 00 DEGREES 07 MINUTES 36 SECONDS EAST, 1117.17 FEET TO THE NORTH LINE OF SAID CHERRYWOOD FOREST ALSO BEING THE SOUTH LINE OF LOT 3 OF AFORESAID CSM 14062; THENCE ALONG THE SOUTH LINE OF SAID LOT 3 OF CSM 14062 NORTH 89 DEGREES 41 MINUTES 05 SECONDS EAST, 369.92 FEET TO THE WESTERLY MOST LINE OF SAID LOT 3 OF CSM 14062 ALSO BEING THE EAST LINE OF OUTLOT 1 OF WELCOME HOME RECORDED IN VOLUME 60-091B OF PLATS OF DANE COUNTY ON PAGES 507-508 AS DOCUMENT NO. 5398765; THENCE ALONG SAID EAST LINE OF OUTLOT 1 OF WELCOME HOME NORTH 00 DEGREES 08 MINUTES 26 SECONDS EAST, 1060.43 FEET TO THE NORTHERLY RIGHT-OF-WAY LINE OF MANISTEE WAY; THENCE ALONG SAID NORTHERLY RIGHT-OF-WAY LINE OF MANISTEE WAY NORTH 89 DEGREES 29 MINUTES 22 SECONDS WEST, 450.79 FEET TO A POINT OF TANGENT CURVE; THENCE NORTHWESTERLY 38.62 FEET ALONG THE ARC OF A CURVE TO THE RIGHT, HAVING A RADIUS OF 25.00 FEET AND A LONG CHORD THAT BEARS NORTH 44 DEGREES 08 MINUTES 58 SECONDS WEST, 34.89 FEET TO A POINT OF TANGENT ON THE EASTERLY RIGHT-OF-WAY OF WELCOME DRIVE; THENCE ALONG SAID EASTERLY RIGHT-OF-WAY OF WELCOME DRIVE NORTH 00 DEGREES 06 MINUTES 01 SECONDS EAST, 379.80 FEET TO A POINT OF TANGENT CURVE; THENCE NORTHEASTERLY 39.36 FEET ALONG THE ARC OF A CURVE TO THE RIGHT, HAVING A RADIUS OF 25.00 FEET AND A LONG CHORD THAT BEARS NORTH 45 DEGREES 12 MINUTES 16 SECONDS EAST, 35.42 FEET TO A POINT OF TANGENT ON THE AFORESAID SOUTHERLY RIGHT-OF-WAY OF MINERAL POINT ROAD; THENCE ALONG SAID SOUTHERLY RIGHT-OF-WAY OF MINERAL POINT ROAD ALSO BEING THE WESTERLY MOST SEGMENT ALONG THE NORTHERN BOUNDARY OF AFORESAID LOT 1 OF CSM 14753 SOUTH 89 DEGREES 41 MINUTES 30 SECONDS EAST, 182.83 FEET; THENCE CONTINUING ALONG THE BOUNDARY OF SAID LOT 1 OF CSM 14753 SOUTH 00 DEGREES 17 MINUTES 40 SECONDS WEST, 258.00 FEET; THENCE CONTINUING ALONG SAID BOUNDARY OF LOT 1 OF CSM 14753 SOUTH 89 DEGREES 53 MINUTES 21 SECONDS EAST, 330.00 FEET; THENCE CONTINUING ALONG SAID BOUNDARY OF LOT 1 OF CSM 14753 NORTH 00 DEGREES 17 MINUTES 40 SECONDS EAST, 256.86 FEET TO THE AFORESAID SOUTHERLY RIGHT-OF-WAY LINE OF MINERAL POINT ROAD; THENCE ALONG SAID SOUTHERLY RIGHT-OF-WAY LINE OF MINERAL POINT ROAD SOUTH 89 DEGREES 41 MINUTES 30 SECONDS EAST, 235.33 FEET TO A WESTERLY LINE OF AFORESAID LOT 3 OF CSM 14062; THENCE CONTINUING ALONG SAID RIGHT-OF-WAY OF MINERAL POINT ROAD NORTH 00 DEGREES 08 MINUTES 09 SECONDS EAST, 10.00 FEET; THENCE CONTINUING ALONG SAID RIGHT-OF-WAY OF MINERAL POINT ROAD SOUTH 89 DEGREES 41 MINUTES 30 SECONDS EAST, 233.49 FEET BACK TO THE POINT OF BEGINNING.

SAID PARCEL CONTAINS 5,550, 488 SQUARE FEET OR 127.42 ACRES INCLUDING THE RIGHT-OF-WAY OF PIONEER ROAD OR 5,512,650 SQUARE FEET OR 126.55 ACRES EXCLUDING THE EXISTING RIGHT-OF-WAY OF PIONEER ROAD

DATED THIS 7TH DAY OF SEPTEMBER, 2019.

JULIUS W. SMITH, S-3091
WISCONSIN PROFESSIONAL LAND SURVEYOR

REVISED THIS XXTH DAY OF XXXXXXXXXX, 201X.

OFFICE OF THE REGISTER OF DEEDS _____ COUNTY, WISCONSIN

RECEIVED FOR RECORD _____
20___ AT _____ O'CLOCK _____ M AS

DOCUMENT # _____

IN VOL. _____ OF PLATS,

ON PAGE(S) _____

REGISTER OF DEEDS _____

There are no objections to this plat with respect to Secs. 236.15, 236.16, 236.20 and 236.21(1) and (2), Wis. Stats. as provided by s. 236.12, Wis. Stats.

Certified _____, 20___

Department of Administration

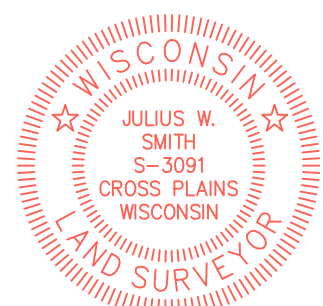

PREPARED FOR:
HAEN REAL ESTATE
9 HAWKS LANDING CIRCLE
P.O. BOX 44129
VERONA, WI 53593



SURVEYED BY:
WYSER ENGINEERING
312 EAST MAIN STREET
MOUNT HOREB, WI 53572
www.wyserengineering.com